

Belt Drive Type Actuator **IF**



# IF

## Belt Drive Type Actuator



IF Series base structure deformation under a given amount of force.



Deformation of a competitor's base structure under the same amount of force.

### Features:

- Timing belt-type actuator using AC servo motor and incremental optical encoder.
- Maximum stroke length: 2500mm; maximum speed: 1750mm/s.
- Highly rigid base structure.
- Double slider option increases moment capability and allows greater overhang load length.
- Urethane timing belt is highly durable and generates minimal particles.
- Base structure is highly resistant to torsional deformation and warp.

### Double Slider Option:

The double slider option provides the added feature and ability to vary the distance between the two sliders. One slider is mounted to the timing belt and linear guide, while the other is mounted only to the linear guide. The double slider option increases the overhang load capability of the IF Series actuator and adds a new dimension of flexibility to accommodate a wide variety of configurations.

### Load Moment / Overhang Load Length

The IF series W Slider is an option that can be chosen (An addition of a free-moving slider). The dynamic movement and overhang load will be dependent on the span of the 2 sliders. Please use the following examples as reference.

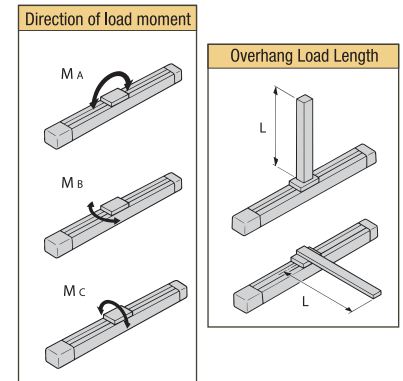
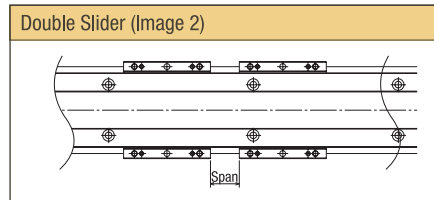
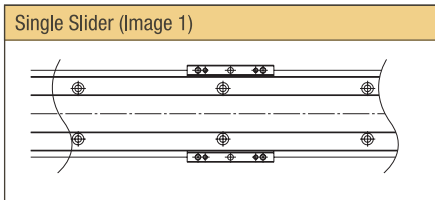

Type			Load Moment N · m (Kgf · m)	Overhang Load Length (mm)
IF-SA-60 IF-SA-100	Image ①	Single Slider	Ma : 28.4 (2.9) Mb : 40.2 (4.1) Mc : 65.7 (6.7)	Ma : Less than 450 Mb, Mc : Less than 450
	Image ②	Double Slider (45mm span)	Ma : 130.3 (13.3) Mb : 185.2 (18.9) Mc : 106.8 (10.9)	Ma : Less than 1125 Mb, Mc : Less than 1125
		Double Slider (60mm span)	Ma : 142.0 (14.5) Mb : 203.8 (20.8) Mc : 106.8 (10.9)	Ma : Less than 1200 Mb, Mc : Less than 1200
IF-MA-200 IF-MA-400	Image ①	Single Slider	Ma : 69.6 (7.1) Mb : 99.0 (10.1) Mc : 161.7 (16.5)	Ma : Less than 600 Mb, Mc : Less than 600
	Image ②	Double Slider (55mm span)	Ma : 316.5 (32.3) Mb : 450.8 (46.0) Mc : 262.0 (26.8)	Ma : Less than 1475 Mb, Mc : Less than 1475
		Double Slider (80mm span)	Ma : 350.0 (35.8) Mb : 500.0 (51.0) Mc : 262.0 (26.8)	Ma : Less than 1600 Mb, Mc : Less than 1600

(\*) Load moment calculated by assuming a traveled distance of 10,000km (fw=1.2)

# [IF Series]

**IF** Series - Type - Encoder Model - Motor Type - Stroke - Applicable Controller - Cable Length - Option

IF	Standard Type	A	Absolute	60	60W	200	200mm	T1	XSEL-J/K	N	No Cable	AQ	AQ Seal	LM	Master Axis of Synchronized Specification
		I	Incremental	100	100W	~	~		SCON	S	3m	C	Creep Sensor	NM	Reverse Home Specification
SA1L	Compact Standard Type	MA1L	Medium Standard Type	200	200W	2500	2500mm	T2	SSEL	M	5m	CL	Creep Sensor Mounting Reversed	RT	Guide with Ball Retention Mechanism
SA2L	Compact Motor On Side	MA2L	Medium Motor On Side	400	400W	In 100mm steps			XEL-P/Q	X	<input type="checkbox"/> Specified Length	L	Limit Switch	S	Slave Axis of Synchronized Specification
SA3L	Compact Motor On Bottom	MA3L	Medium Motor On Bottom									LL	Limit Switch Mounting Reversed	W	Double Slider
SA1R	Compact Standard Type Motor Mounting Reversed	MA1R	Medium Standard Type Motor Mounting Reversed									LLM	Synchronized Specification Sensor Mounting Reversed		
SA2R	Compact Motor On Side Motor Mounting Reversed	MA2R	Medium Motor On Side Motor Mounting Reversed												
SA3R	Compact Motor On Bottom Motor Mounting Reversed	MA3R	Medium Motor On Bottom Motor Mounting Reversed												

## IF Series Motor Mounting Positions

The positions of the motor and sensors can be changed to the 6 types as shown in the following figures, depending on the actuator installation requirements. With these changes, the motor position can be changed according to the installation environment. Note that in case of the motor on side and motor on bottom, the motor position becomes lower than the slider and there is thus no risk of contacting the load. Moreover, if optional creep sensor (C) and/or origin limit switch (L) are to be mounted, they shall be mounted as standard in the case the motor mount direction is L (to the right seen from the motor side, symbols C and L) and as reversed in the case the motor mount direction is R (to the left seen from the motor side, symbols CL and LL).

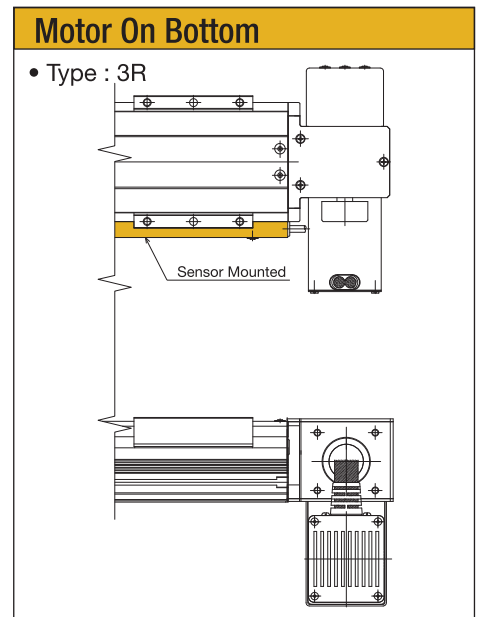
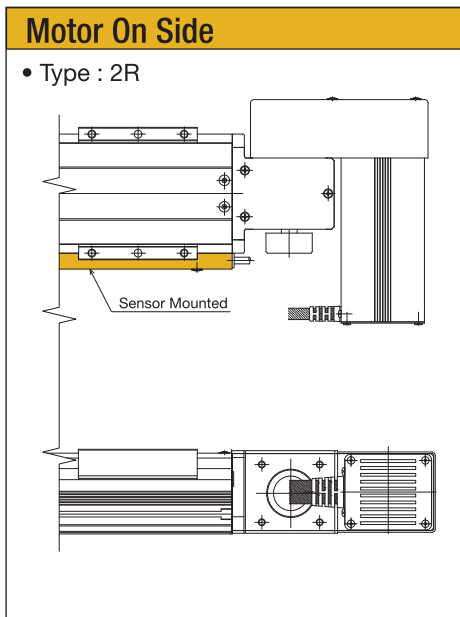
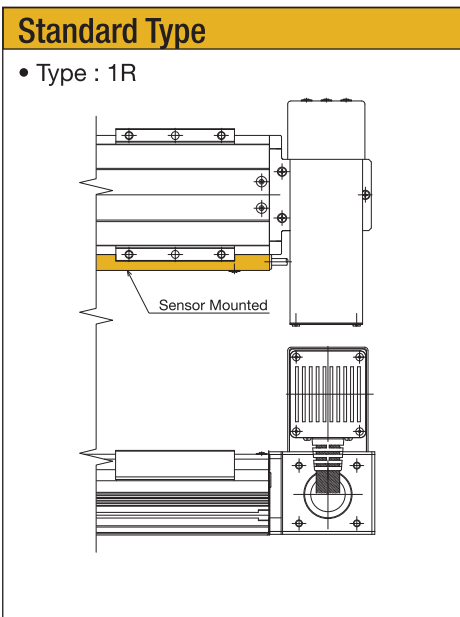
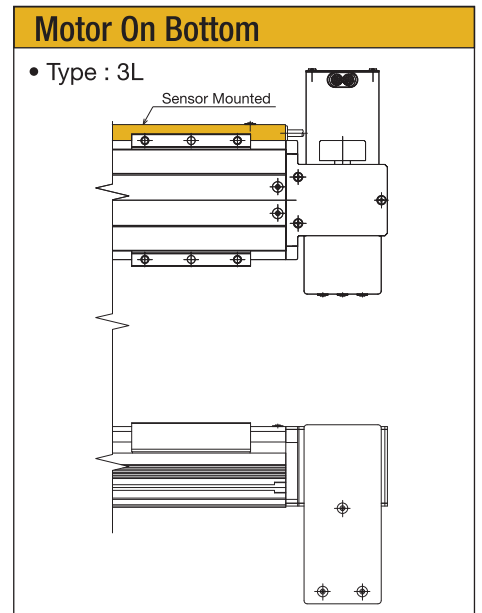
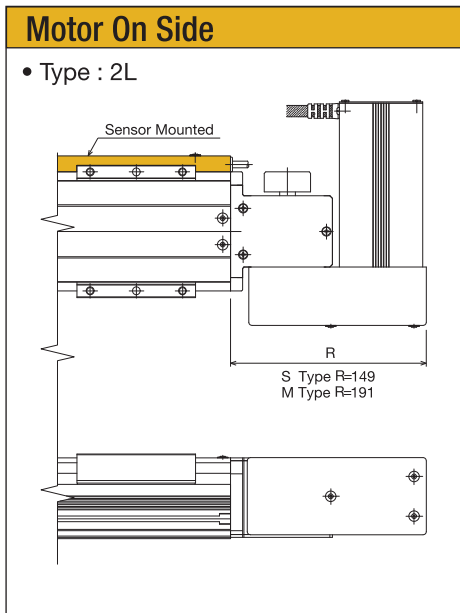
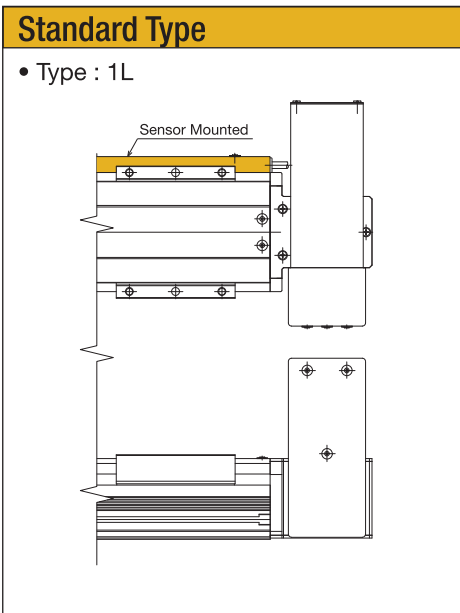

# IF-SA-60

Single-Axis Robot, Compact Belt Type, Actuator Width 90mm, 60W



Model Designation	IF	—	—	—	60	—	—	—	—	—
Series	Type	Encoder Model	Motor Type	Stroke	Applicable Controller	Cable Length	Option			
SA1L: Standard	SA2L: Motor on Side	A: Absolute	60:60W	200:200mm	T1:XSEL-J/K	N: No Cable	Refer to the options table below			
SA3L: Motor on Bottom	SA1R: Motor, Reversed	I: Incremental		5	T2: SCON	S: 3m				
SA2R: Horizontal Motor, Reversed	SA3R: Motor on Bottom, Reversed			2000:2000mm (in 100mm steps)	SSEL	M: 5m				
					XSEL-P/Q	X□□: Specified Length				

## Models/Specifications

Model	Encoder Type	Motor Output (W)	Motor Mounting Position (Note 1)	Stroke 100mm Unit (mm)	Speed (mm/s)	Load Capacity (Note 2)		Rated Thrust (N)
						Horizontal (kg)	Vertical (kg)	
IF-SA1 [1]-[2]-60-[3]-[4]-[5]-[6]	Absolute Incremental	60	Standard	200~2000	1~1750	5	Horizontal Only	25.8
IF-SA2 [1]-[2]-60-[3]-[4]-[5]-[6]			Motor on Side					
IF-SA3 [1]-[2]-60-[3]-[4]-[5]-[6]			Motor on Bottom					

\* [1]: Motor mounting direction (L: Standard, R: Reversed), [2]: Encoder Type, [3]: Stroke, [4]: Applicable Controller, [5]: Cable Length, and [6]: Option.

## Options

Name	Model	Remarks
AQ Seal	AQ	
Creep Sensor (Note 3)	C	(CL: Reversed Mounting Side)
Home Limit Switch (Note 3)	L	(LL: Reversed Mounting Side)
Reversed Home Specification	NM	
Guide with Ball Retention Mechanism	RT	
Double Slider	W	

## Common Specifications

Positioning Repeatability	±0.08mm
Drive Method	Timing Belt
Lost Motion	0.1mm max.
Static Allowable Moment	Please refer to page 1
Dynamic Allowable Moment (Note 4)	Please refer to page 1
Overhang Length	Please refer to page 1
Base	Material: Aluminum with white alumite treatment
Applicable Controller	T1: XSEL-J/K T2: XSEL-P/Q, SSEL, SCON
Cable Length (Note 5)	N: No Cable, S: 3m, M: 5m, X□□: Specified Length
Surrounding Air Temp/Humidity	0 to 40°C, 85% RH (non-condensing)

## Dimensions

### Single Slider

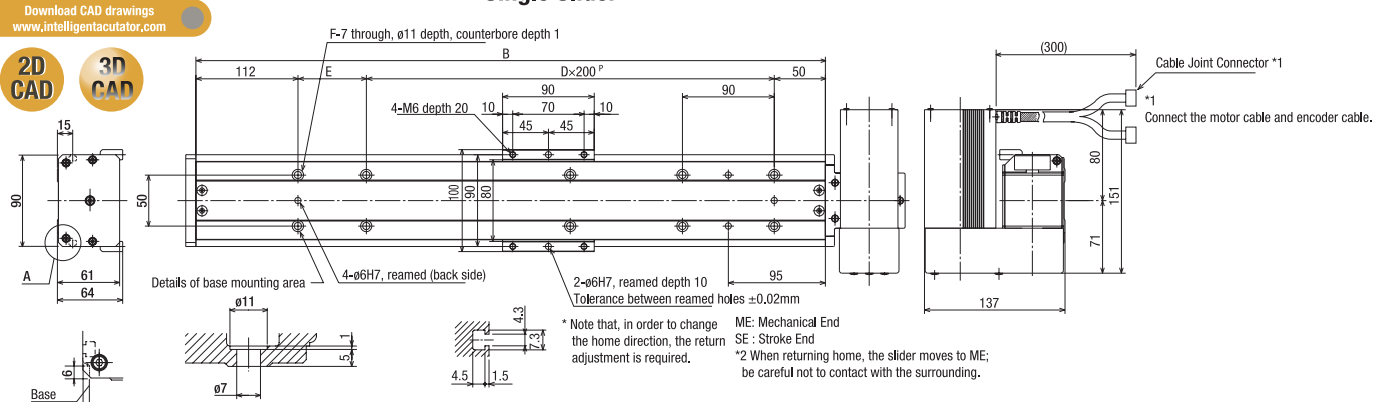

### T-slot Dimensions

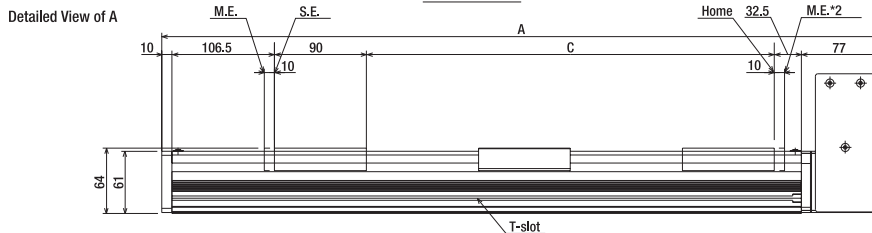

### Double Slider

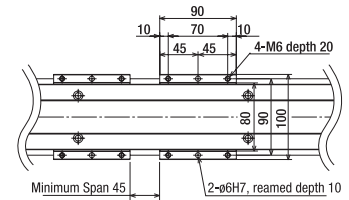

\* In the case of the double sliders, the stroke becomes shorter by the length of slider plus the span between sliders.

Stroke	200	300	400	500	600	700	800	900	1000	1100	1200	1300	1400	1500	1600	1700	1800	1900	2000
A	516	616	716	816	916	1016	1116	1216	1316	1416	1516	1616	1716	1816	1916	2016	2116	2216	2316
B	429	529	629	729	829	929	1029	1129	1229	1329	1429	1529	1629	1729	1829	1929	2029	2129	2229
C	200	300	400	500	600	700	800	900	1000	1100	1200	1300	1400	1500	1600	1700	1800	1900	2000
D	1	1	2	2	3	3	4	4	5	5	6	6	7	7	8	8	9	9	10
E	67	167	67	167	67	167	67	167	67	167	67	167	67	167	67	167	67	167	67
F	8	8	10	10	12	12	14	14	16	16	18	18	20	20	22	22	24	24	26
Mass (kg)	4.4	4.9	5.4	5.9	6.4	6.8	7.3	7.8	8.3	8.8	9.2	9.7	10.2	10.7	11.2	11.6	12.1	12.6	13.1
Max Speed (mm/s)	1750																		

## Applicable Controller Specifications

Applicable Controller	Max number of controlled axes	Connectable Encoder Type	Operating Method	Power Supply Voltage
X-SEL-P/Q	6 axes	Absolute Incremental	Program	Single-Phase 3-phase 200 VAC
X-SEL-J/K	4 axes			Single-Phase 100/200 VAC
SSEL	2 axes		Positioner Pulse Train	
SCON	1 axis			



- (Note 1) Refer to page 2 for the detailed explanation on the motor mounting positions.
- (Note 2) The load capacity is the value obtained when the robot is operated at the acceleration of 0.3G.
- (Note 3) Note that if creep sensor and home limit switch are to be added, the sensor mounting side is determined by the motor mounting direction due to its configuration (See page 2 for details)
- (Note 4) In case the traveling life is 10,000km.
- (Note 5) The maximum cable length is 30m. Specify the length in the unit of m. (Example: X08 = 8m)

# IF-SA-100

Single-Axis Robot, Compact Belt Type, Actuator Width 90mm, 100W



**Model Designation IF** — [ ] — [ ] — **100** — [ ] — [ ] — [ ] — [ ]

Series	Type	Encoder Model	Motor Type	Stroke	Applicable Controller	Cable Length	Option
SA1L: Standard SA2L: Motor on Side SA3L: Motor on Bottom SA1R: Motor, Reversed SA2R: Horizontal Motor, Reversed SA3R: Motor on Bottom, Reversed		A: Absolute I: Incremental	100:100W	200:200mm S 2000:2000mm (# 100mm steps)	T1:XSEL-J/K T2:SCON SSEL XSEL-P/Q	N: No Cable S: 3m M: 5m X□□: Specified Length	Refer to the options table below

## Models/Specifications

Model	Encoder Type	Motor Output (W)	Motor Mounting Position (Note 1)	Stroke 100mm Unit (mm)	Speed (mm/s)	Load Capacity (Note 2)		Rated Thrust (N)
						Horizontal (kg)	Vertical (kg)	
IF-SA1 [1]-[2]-100-[3]-[4]-[5]-[6]	Absolute Incremental	100	Standard	200~2000	1~1750	10	Horizontal Only	43.0
IF-SA2 [1]-[2]-100-[3]-[4]-[5]-[6]			Motor on Side					
IF-SA3 [1]-[2]-100-[3]-[4]-[5]-[6]			Motor on Bottom					

\* [1]: Motor mounting direction (L: Standard, R: Reversed), [2]: Encoder Type, [3]: Stroke, [4]: Applicable Controller, [5]: Cable Length, and [6]: Option.

## Options

Name	Model	Remarks
AQ Seal	AQ	
Creep Sensor (Note 3)	C	(CL: Reversed Mounting Side)
Home Limit Switch (Note 3)	L	(LL: Reversed Mounting Side)
Reversed Home Specification	NM	
Guide with Ball Retention Mechanism	RT	
Double Slider	W	

## Common Specifications

Positioning Repeatability	±0.08mm
Drive Method	Timing Belt
Lost Motion	0.1mm max.
Static Allowable Moment	Please refer to page 1
Dynamic Allowable Moment (Note 4)	Please refer to page 1
Overhang Length	Please refer to page 1
Base	Material: Aluminum with white alumite treatment
Applicable Controller	T1: XSEL-J/K T2: XSEL-P/Q, SSEL, SCON
Cable Length (Note 5)	N: No Cable, S: 3m, M: 5m, X□□: Specified Length
Surrounding Air Temp/Humidity	0 to 40°C, 85% RH (non-condensing)

## Dimensions

### Single Slider

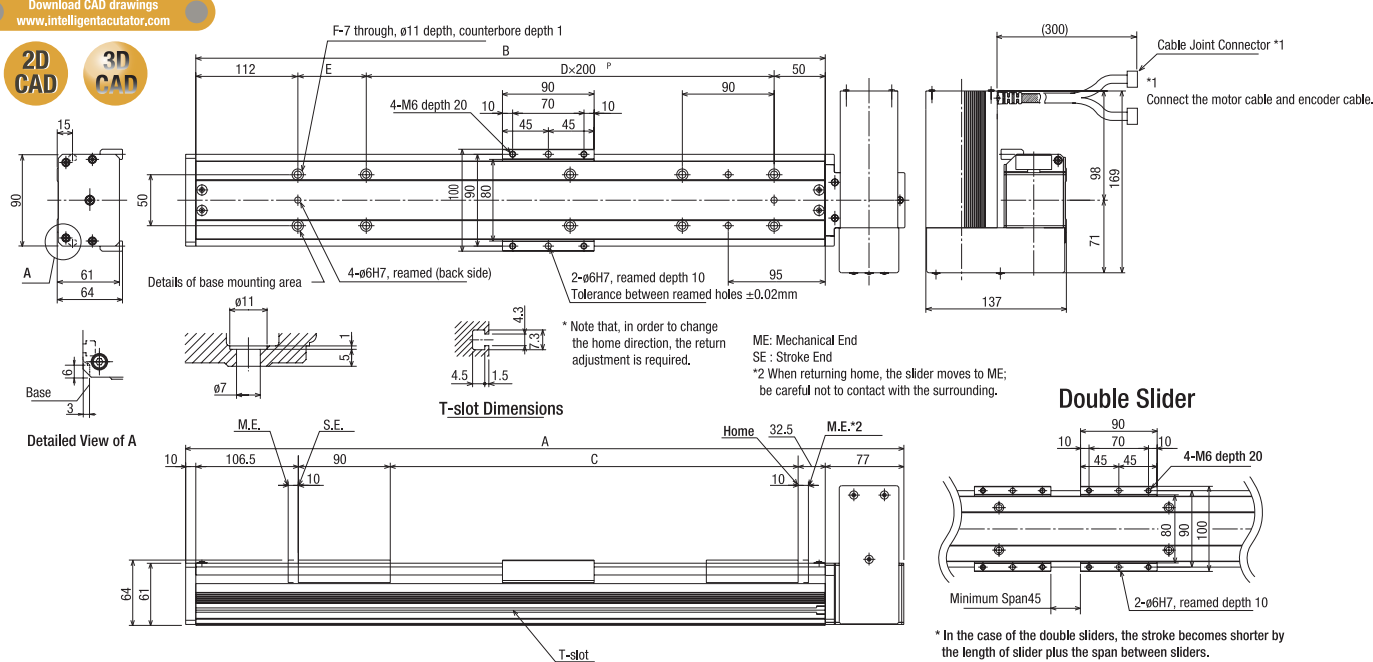

Stroke	200	300	400	500	600	700	800	900	1000	1100	1200	1300	1400	1500	1600	1700	1800	1900	2000
A	516	616	716	816	916	1016	1116	1216	1316	1416	1516	1616	1716	1816	1916	2016	2116	2216	2316
B	429	529	629	729	829	929	1029	1129	1229	1329	1429	1529	1629	1729	1829	1929	2029	2129	2229
C	200	300	400	500	600	700	800	900	1000	1100	1200	1300	1400	1500	1600	1700	1800	1900	2000
D	1	1	2	2	3	3	4	4	5	5	6	6	7	7	8	8	9	9	10
E	67	167	67	167	67	167	67	167	67	167	67	167	67	167	67	167	67	167	67
F	8	8	10	10	12	12	14	14	16	16	18	18	20	20	22	22	24	24	26
Mass (kg)	4.6	5.1	5.6	6.1	6.6	7.0	7.5	8.0	8.5	9.0	9.4	9.9	10.4	10.9	11.4	11.8	12.3	12.8	13.3
Max Speed (mm/s)	1750																		

## Applicable Controller Specifications

Applicable Controller	Max number of controlled axes	Connectable Encoder Type	Operating Method	Power Supply Voltage
X-SEL-P/Q	6 axes	Absolute Incremental	Program	Single-Phase 3-phase 200 VAC
X-SEL-J/K	4 axes			Single-Phase 100/200 VAC
SSEL	2 axes			
SCON	1 axis			



- (Note 1) Refer to page 2 for the detailed explanation on the motor mounting positions.
- (Note 2) The load capacity is the value obtained when the robot is operated at the acceleration of 0.3G.
- (Note 3) Note that if creep sensor and home limit switch are to be added, the sensor mounting side is determined by the motor mounting direction due to its configuration (See page 2 for details)
- (Note 4) In case the traveling life is 10,000km.
- (Note 5) The maximum cable length is 30m. Specify the length in the unit of m. (Example: X08 = 8m)



# IF-MA-200

Single-Axis Robot, Medium Belt Type, Actuator Width 120mm, 200W



<b>Model Designation</b>	<b>IF</b>			<b>200</b>					
Series	Type	Encoder Model	Motor Type	Stroke	Applicable Controller	Cable Length	Option		
MA1L: Standard MA2L: Motor on Side MA3L: Motor on Bottom MA1R: Motor, Reversed MA2R: Horizontal Motor, Reversed MA3R: Motor on Bottom, Reversed		A: Absolute I: Incremental	200:200W	200:200mm S 2500:2500mm (in 100mm steps)	T1:XSEL-J/K T2:SCON SSEL XSEL-P/Q	N: No Cable S: 3m M: 5m X□□: Specified Length	Refer to the options table below		

## Models/Specifications

Model	Encoder Type	Motor Output (W)	Motor Mounting Position (Note 1)	Stroke 100mm Unit (mm)	Speed (mm/s)	Load Capacity (Note 2)		Rated Thrust (N)
						Horizontal (kg)	Vertical (kg)	
IF-MA1 [1]-[2]-200-[3]-[4]-[5]-[6]	Absolute Incremental	200	Standard	200~2500	1~1750	20	Horizontal Only	85.7
IF-MA2 [1]-[2]-200-[3]-[4]-[5]-[6]			Motor on Side					
IF-MA3 [1]-[2]-200-[3]-[4]-[5]-[6]			Motor on Bottom					

\* [1]: Motor mounting direction (L: Standard, R: Reversed), [2]: Encoder Type, [3]: Stroke, [4]: Applicable Controller, [5]: Cable Length, and [6]: Option.

## Options

Name	Model	Remarks
AQ Seal	AQ	
Creep Sensor (Note 3)	C	(CL: Reversed Mounting Side)
Home Limit Switch (Note 3)	L	(LL: Reversed Mounting Side)
Reversed Home Specification	NM	
Guide with Ball Retention Mechanism	RT	
Double Slider	W	

## Common Specifications

Positioning Repeatability	±0.08mm
Drive Method	Timing Belt
Lost Motion	0.1mm max.
Static Allowable Moment	Please refer to page 1
Dynamic Allowable Moment (Note 4)	Please refer to page 1
Overhang Length	Please refer to page 1
Base	Material: Aluminum with white alumite treatment
Applicable Controller	T1: XSEL-J/K T2: XSEL-P/Q, SSEL, SCON
Cable Length (Note 5)	N: No Cable, S: 3m, M: 5m, X□□: Specified Length
Surrounding Air Temp/Humidity	0 to 40°C, 85% RH (non-condensing)

## Dimensions

### Single Slider

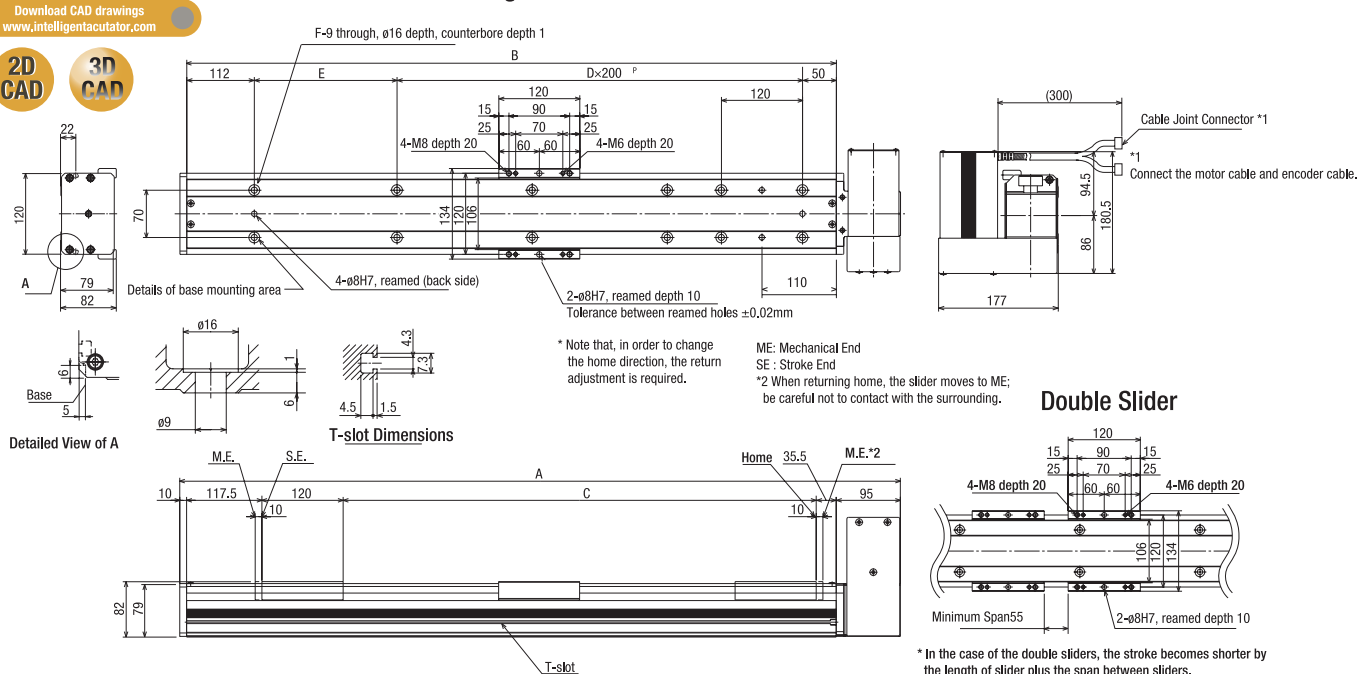

Stroke	200	300	400	500	600	700	800	900	1000	1100	1200	1300	1400	1500	1600	1700	1800	1900	2000	2100	2200	2300	2400	2500
A	578	678	778	878	978	1078	1178	1278	1378	1478	1578	1678	1778	1878	1978	2078	2178	2278	2378	2478	2578	2678	2778	2878
B	473	573	673	773	873	973	1073	1173	1273	1373	1473	1573	1673	1773	1873	1973	2073	2173	2273	2373	2473	2573	2673	2773
C	200	300	400	500	600	700	800	900	1000	1100	1200	1300	1400	1500	1600	1700	1800	1900	2000	2100	2200	2300	2400	2500
D	1	1	2	2	3	3	4	4	5	5	6	6	7	7	8	8	9	9	10	10	11	11	12	12
E	111	211	111	211	111	211	111	211	111	211	111	211	111	211	111	211	111	211	111	211	111	211	111	211
F	8	8	10	10	12	12	14	14	16	16	18	18	20	20	22	22	24	24	26	26	28	28	30	30
Mass (kg)	7.7	8.5	9.3	10.0	10.8	11.6	12.4	13.2	14.0	14.8	15.6	16.4	17.2	17.9	18.7	19.5	20.3	21.1	21.9	22.7	23.5	24.3	25.1	25.8
Max Speed (mm/s)	1750																							

## Applicable Controller Specifications

Applicable Controller	Max number of controlled axes	Connectable Encoder Type	Operating Method	Power Supply Voltage
X-SEL-P/Q	6 axes	Absolute Incremental	Program	Single-Phase 3-phase 200 VAC
X-SEL-J/K	4 axes			Single-Phase 100/200 VAC
SSEL	2 axes		Positioner Pulse Train	Single-Phase 100/200 VAC
SCON	1 axis			



- (Note 1) Refer to page 2 for the detailed explanation on the motor mounting positions.
- (Note 2) The load capacity is the value obtained when the robot is operated at the acceleration of 0.3G.
- (Note 3) Note that if creep sensor and home limit switch are to be added, the sensor mounting side is determined by the motor mounting direction due to its configuration (See page 2 for details)
- (Note 4) In case the traveling life is 10,000km.
- (Note 5) The maximum cable length is 30m. Specify the length in the unit of m. (Example: X08 = 8m)

# IF-MA-400

Single-Axis Robot, Medium Belt Type, Actuator Width 120mm, 400W



<b>Model Designation</b>	<b>IF</b>			<b>400</b>				
Series	Type	Encoder Model	Motor Type	Stroke	Applicable Controller	Cable Length	Option	
MA1L: Standard MA2L: Motor on Side MA3L: Motor on Bottom MA1R: Motor, Reversed MA2R: Horizontal Motor, Reversed MA3R: Motor on Bottom, Reversed		A: Absolute I: Incremental	400-400W	200:200mm S 2500:2500mm (in 100mm steps)	T1: XSEL-J/K T2: SCON SSEL XSEL-P/Q	N: No Cable S: 3m M: 5m X□□: Specified Length	Refer to the options table below	

## Models/Specifications

Model	Encoder Type	Motor Output (W)	Motor Mounting Position (Note 1)	Stroke 100mm Unit (mm)	Speed (mm/s)	Load Capacity (Note 2)		Rated Thrust (N)
						Horizontal (kg)	Vertical (kg)	
IF-MA1 [1]-[2]-400-[3]-[4]-[5]-[6]	Absolute Incremental	400	Standard	200~2500	1~1750	40	Horizontal Only	171.5
IF-MA2 [1]-[2]-400-[3]-[4]-[5]-[6]			Motor on Side					
IF-MA3 [1]-[2]-400-[3]-[4]-[5]-[6]			Motor on Bottom					

\* [1]: Motor mounting direction (L: Standard, R: Reversed), [2]: Encoder Type, [3]: Stroke, [4]: Applicable Controller, [5]: Cable Length, and [6]: Option.

## Options

Name	Model	Remarks
AQ Seal	AQ	
Creep Sensor (Note 3)	C	(CL: Reversed Mounting Side)
Home Limit Switch (Note 3)	L	(LL: Reversed Mounting Side)
Reversed Home Specification	NM	
Guide with Ball Retention Mechanism	RT	
Double Slider	W	

## Common Specifications

Positioning Repeatability	±0.08mm
Drive Method	Timing Belt
Lost Motion	0.1mm max.
Static Allowable Moment	Please refer to page 1
Dynamic Allowable Moment (Note 4)	Please refer to page 1
Overhang Length	Please refer to page 1
Base	Material: Aluminum with white alumite treatment
Applicable Controller	T1: XSEL-J/K T2: XSEL-P/Q, SSEL, SCON
Cable Length (Note 5)	N: No Cable, S: 3m, M: 5m, X□□: Specified Length
Surrounding Air Temp/Humidity	0 to 40°C, 85% RH (non-condensing)

## Dimensions

### Single Slider

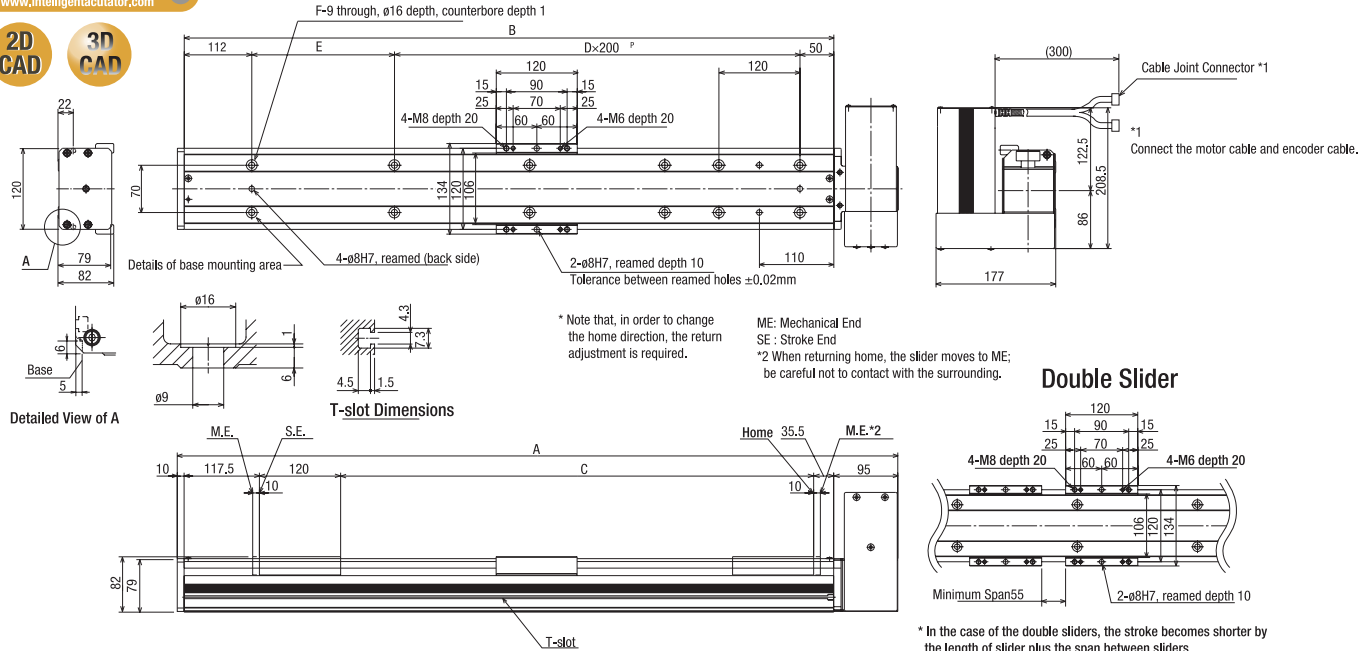

Stroke	200	300	400	500	600	700	800	900	1000	1100	1200	1300	1400	1500	1600	1700	1800	1900	2000	2100	2200	2300	2400	2500	
A	578	678	778	878	978	1078	1178	1278	1378	1478	1578	1678	1778	1878	1978	2078	2178	2278	2378	2478	2578	2678	2778	2878	
B	473	573	673	773	873	973	1073	1173	1273	1373	1473	1573	1673	1773	1873	1973	2073	2173	2273	2373	2473	2573	2673	2773	
C	200	300	400	500	600	700	800	900	1000	1100	1200	1300	1400	1500	1600	1700	1800	1900	2000	2100	2200	2300	2400	2500	
D	1	1	2	2	3	3	4	4	5	5	6	6	7	7	8	8	9	9	10	10	11	11	12	12	
E	111	211	211	211	211	211	211	211	211	211	211	211	211	211	211	211	211	211	211	211	211	211	211	211	
F	8	8	10	10	12	12	14	14	16	16	18	18	20	20	22	22	24	24	26	26	28	28	30	30	
Mass (kg)	8.2	9.0	9.8	10.5	11.3	12.1	12.9	13.7	14.5	15.3	16.1	16.9	17.7	18.4	19.2	20.0	20.8	21.6	22.4	23.2	24.0	24.8	25.6	26.3	
Max Speed (mm/s)	1750																								

## Applicable Controller Specifications

Applicable Controller	Max number of controlled axes	Connectable Encoder Type	Operating Method	Power Supply Voltage
X-SEL-P/Q	6 axes	Absolute Incremental	Program	Single-Phase 3-phase 200 VAC
X-SEL-J/K	4 axes			Single-Phase 100/200 VAC
SSEL	2 axes		Positioner Pulse Train	Single-Phase 100/200 VAC
SCON	1 axis			Single-Phase 100/200 VAC



- (Note 1) Refer to page 2 for the detailed explanation on the motor mounting positions.
- (Note 2) The load capacity is the value obtained when the robot is operated at the acceleration of 0.3G.
- (Note 3) Note that if creep sensor and home limit switch are to be added, the sensor mounting side is determined by the motor mounting direction due to its configuration (See page 2 for details)
- (Note 4) In case the traveling life is 10,000km.
- (Note 5) The maximum cable length is 30m. Specify the length in the unit of m. (Example: X08 = 8m)



***IAI America, Inc.***

Headquarters: 2690 W. 237th Street Torrance, CA 90505  
Chicago Office: 1261 Hamilton Parkway Itasca, IL 60143  
Atlanta Office: 1220 Kennestone Circle Suite E, Marietta, GA 30066

Website: [www.intelligentactuator.com](http://www.intelligentactuator.com)

Due to product improvements, the information presented in this catalog is subject to change without notice

***IAI (Shanghai) Co.,Ltd.***

SHANGHAI JIAHUA BUSINESS CENTER A8404.808  
Hongqiao Rd. shanghai 200030, China

***IAI Industrieroboter GmbH***

Ober der Röth 4, D-65824 Schwalbach am Taunus, Germany

